

A GREATER MEASURE OF CONFIDENCE

KEITHLEY

Making Precision Low Current and High Resistance Measurements

Introduction 2 **Low Current Measurements** 2 Measurement Circuit 2 Leakage Currents and Guarding 3 Noise and Source Resistance 3 Zero Drift 4 Generated Currents 4 Overload Protection 6 AC Interference and Damping 6 Using a Coulombmeter to Measure Low Current 7 **High Resistance Measurements** 8 Constant-Voltage Method 8 Constant-Current Method 8 Guarding 9 Settling Time 10 **Low-I Application** 11 **High-R Application** 12 **Selector Guide** 13 **Glossary** 14

Low Current Measurements

Introduction

Testing and characterizing metallic materials, low temperature superconductors, nanoscale materials, highly doped semiconductors, photo-diode dark currents, and electron beam currents from accelerating devices requires making current measurements at nanoamp levels and below. Either the generated current is low or very low power materials, such as single-atomic-layer graphene, must operate with very low currents to minimize power dissipation and destruction due to self-heating. Similarly, high resistance measurements on insulators, polymers, ceramics, and lightly doped semiconductors also demand the ability to measure very low currents.

Making low current and high resistance measurements requires instrumentation with special capabilities and the use of good measurement techniques. The instruments used to make these high impedance measurements include electrometers, picoammeters, and source-measure units (SMUs). These types of instruments, combined with good measurement practices, will help ensure low level measurements that are accurate and repeatable. This e-handbook offers an overview of the instrumentation and techniques used for making low current and high resistance measurements.

Measurement Circuit

The correct measurement circuit for making a current measurement is shown in **Figure 1**. Ensure that the measurement instrument is at a low voltage point in the circuit. This ensures that the instrument is less likely to be damaged by an over-voltage applied across the instrument. Also, when the instrument is near circuit common, noise voltages tend to be lower. Thus, a better measurement can be obtained.

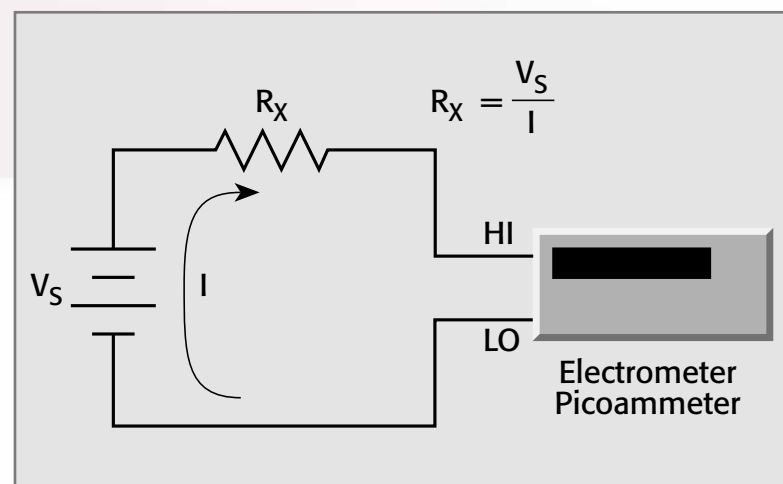

Figure 1: High Resistance Measurement Using External Voltage Source

An ammeter may be represented by an ideal ammeter (I_M) with zero internal resistance, in series with a resistance (R_M), as shown in **Figure 2**. When a current source whose Thevenin equivalent circuit is a voltage (V_S) in series with a source resistance (R_S) is connected to the input of the ammeter, the current is reduced from what it would be with the ideal ammeter ($R_M = 0\Omega$). This reduction is caused by the internal resistance (R_M), which creates an additional voltage drop called the voltage burden (V_B).

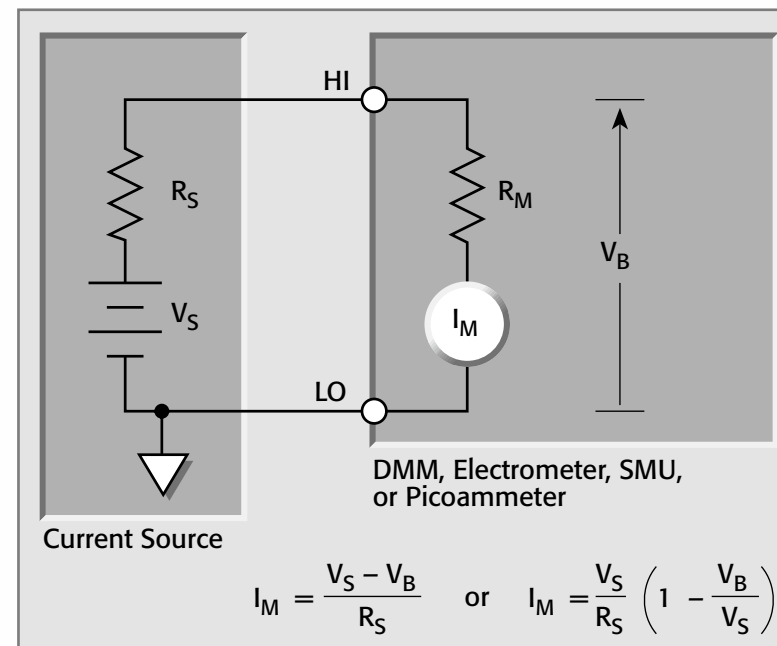

Figure 2: Effects of Voltage Burden on Current Measurement Accuracy

Minimizing voltage burden ensures maximum measurement accuracy. Picoammeters, SMUs, and electrometers all use the feedback ammeter circuit topology shown in **Figure 3**. This topology minimizes voltage burden, typically to a few hundred microvolts. In comparison, a DMM, which uses a shunt resistance technique to measure current, can have voltage burdens of tenths of volts.

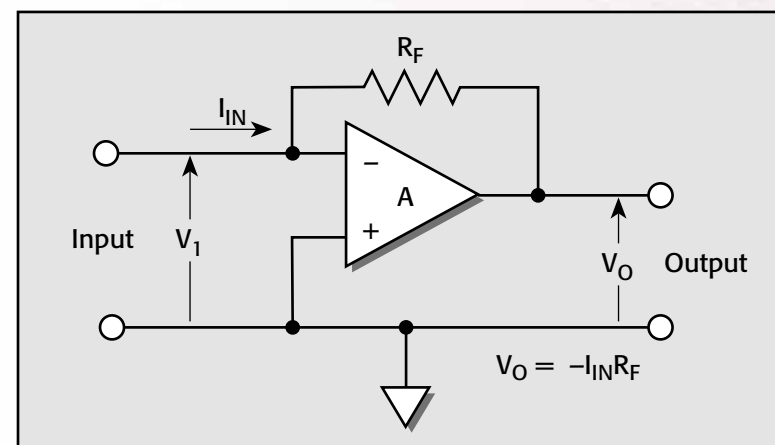

Figure 3: Feedback Ammeter

- Introduction..... 2
- Low Current Measurements
 - Measurement Circuit 2
 - Leakage Currents and Guarding 3
 - Noise and Source Resistance 3
 - Zero Drift.....4
 - Generated Currents 4
 - Overload Protection..... 6
 - AC Interference and Damping 6
 - Using a Coulombmeter to Measure Low Current..... 7
- High Resistance Measurements
 - Constant-Voltage Method..... 8
 - Constant-Current Method..... 8
 - Guarding..... 9
 - Settling Time 10
- Low-I Application: Avalanche Photodiode Reverse Bias Current Measurements..... 11
- High-R Application: Voltage Coefficient Testing of High Ohmic Value Resistors..... 12
- Selector Guide 13
- Glossary 14

Want to Explore Further?

Featured Resources



- **Optimizing Low-Current Measurements and Instruments**
- **High Accuracy Electrometers for Low Current/High Resistance Applications**

Additional Resources

- **Low Current Measurements**
- **High Resistance Measurements**

Ask Us Your Application or Product Question.

Low Current Measurements (continued)

A number of error sources can have serious impacts on low current measurement accuracy. For example, the ammeter may cause measurement errors if not connected properly. The ammeter's voltage burden and input offset current may also affect measurement accuracy. The source resistance of the device under test will affect the noise performance of a feedback ammeter. External sources of error can include leakage current from cables and fixtures, as well as currents generated by triboelectric or piezoelectric effects.

Leakage Currents and Guarding

Leakage currents are generated by stray resistance paths between the measurement circuit and nearby voltage sources. These currents can degrade the accuracy of low current measurements considerably. To reduce leakage currents, use good quality insulators, reduce the level of humidity in the test environment, and use guarding. Guarding will also reduce the effect of shunt capacitance in the measurement circuit.

Using good quality insulators when building the test circuit is one way to reduce leakage currents. Teflon, polyethylene, and sapphire are examples of good quality insulators, but avoid materials like phenolics and nylon.

Humidity may also degrade low current measurements. Different types of insulators will absorb varying amounts of water from the air, so it's best to choose an insulator on which water vapor doesn't readily form a continuous film. Sometimes, this is unavoidable if the material being measured absorbs water easily, so it's best to make the measurements in an environmentally controlled room. In some cases, an insulator may have ionic contaminants, which can generate a spurious current, especially in high humidity.

Guarding is a very effective way to reduce leakage currents. A guard is a low impedance point in the circuit that's at nearly the same potential as the high impedance lead being guarded. For an in-depth discussion of guarding, consult Keithley's online handbook, [Low Level Measurements: Precision DC Current, Voltage, and Resistance Measurements](#).

Noise and Source Resistance

The source resistance of the DUT will affect the noise performance of a feedback ammeter. As the source resistance is reduced, the noise gain of the ammeter will increase.

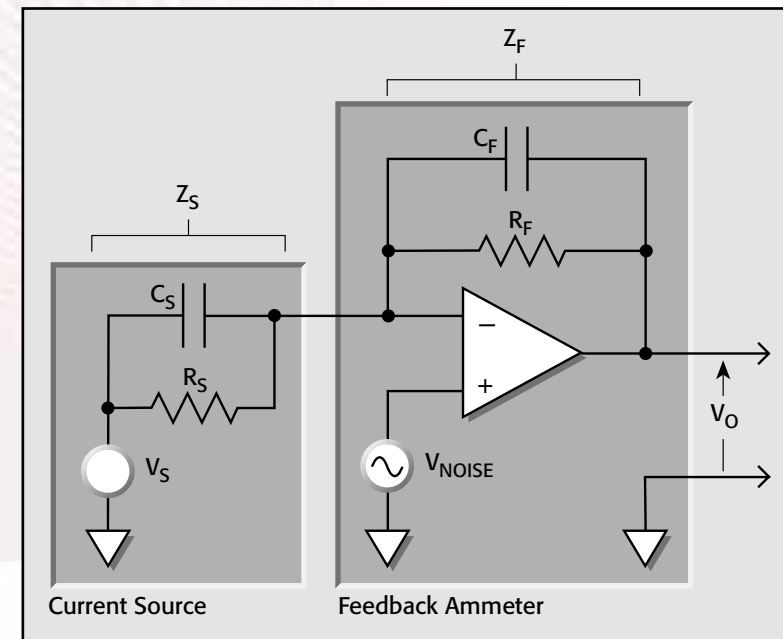

Figure 4: Simplified Model of a Feedback Ammeter

Figure 4 shows a simplified model of a feedback ammeter. R_S and C_S represent the source resistance and source capacitance, V_S is the source voltage, and V_{NOISE} is the noise voltage of the ammeter. Finally, R_F and C_F are the feedback resistance and capacitance respectively. The noise gain of the circuit can be given by the following equation:

$$\text{Output } V_{NOISE} = \text{Input } V_{NOISE} (1 + R_F/R_S)$$

Note that as R_S decreases in value, the output noise increases. For example, when $R_F = R_S$, the input noise is multiplied by a factor of two. Too low a source resistance can have a detrimental effect on noise performance, so there are usually minimum recommended source resistance values based on the measurement range. Table 1 summarizes minimum recommended source resistance values for various measurement ranges for a typical feedback ammeter. Note that the recommended

TABLE 1: Minimum Recommended Source Resistance Values for a Typical Feedback Ammeter

Range	Minimum Recommended Source Resistance	
pA	1	GΩ
nA	1	MΩ
μA	1	kΩ
mA	1	Ω

source resistance varies by measurement range because the R_F value also depends on the measurement range. Refer to the instruction manual for the instrument to be used for the appropriate minimum recommended source resistances.

Source Capacitance

DUT source capacitance will also affect the noise performance of a feedback type ammeter. In general, as source capacitance increases, so does the noise gain.

To see how changes in source capacitance can affect noise gain, let's again refer to the simplified ammeter model in Figure 4. The elements of interest for this discussion are the source capacitance (C_S) and the feedback capacitance (C_F). Taking into account the capacitive reactance of these two elements, our previous noise gain formula must be modified as follows:

$$\text{Output } V_{NOISE} = \text{Input } V_{NOISE} (Z_F/Z_S)$$

Here, Z_F represents the feedback impedance made up of C_F and R_F , while Z_S is the source impedance formed by R_S and C_S . Furthermore,

$$Z_F = \frac{R_F}{\sqrt{(2\pi f R_F C_F)^2 + 1}}$$

and

$$Z_S = \frac{R_S}{\sqrt{(2\pi f R_S C_S)^2 + 1}}$$

Introduction.....	2
Low Current Measurements	
Measurement Circuit.....	2
Leakage Currents and Guarding.....	3
Noise and Source Resistance.....	3
Zero Drift.....	4
Generated Currents.....	4
Overload Protection.....	6
AC Interference and Damping.....	6
Using a Coulombmeter to Measure Low Current.....	7
High Resistance Measurements	
Constant-Voltage Method.....	8
Constant-Current Method.....	8
Guarding.....	9
Settling Time.....	10
Low-I Application: Avalanche Photodiode Reverse Bias Current Measurements.....	11
High-R Application: Voltage Coefficient Testing of High Ohmic Value Resistors.....	12
Selector Guide.....	13
Glossary.....	14

Ask Us Your Application or Product Question.

Low Current Measurements (continued)

Note that as C_s increases in value, Z_s decreases in value, thereby increasing the noise gain. Again, at the point where $Z_s = Z_F$, the input noise is amplified by a factor of two.

Most picoammeters will have a maximum recommended value for C_s . Although it is usually possible to measure at higher source capacitance values by inserting a resistor in series with the ammeter input, remember that any series resistance will increase the voltage burden by a factor of $I_{IN} \cdot R_{SERIES}$. Any series resistance will also increase the RC time constant of the measurement. A series diode, or two diodes in parallel back-to-back, can serve as a useful alternative to a series resistor for this purpose. The diodes can be small-signal types and should be in a light-tight enclosure.

Zero Drift

Zero drift is a gradual change of the indicated zero offset with no input signal. Unless it's corrected by "zeroing," the resulting offset produces an error by adding to the input signal. Drift is normally specified as a function of time and/or temperature. Zero offset over a time period and temperature range will stay within the specified limits. Offset due to step changes in temperatures may exceed the specification before settling. Typical room temperature rates of change (1°C/15 minutes) won't usually cause overshoot.

Most electrometers include a means to correct for zero drift. A ZERO CHECK switch is used to configure most electrometers and picoammeters to display any internal voltage offsets. This feature allows fast checking and adjustment of the amplifier zero. Typically, the instrument is zero corrected while zero check is enabled. This procedure may need to be performed periodically, depending on ambient conditions. Electrometers perform this function with the touch of a button or upon command from the computer.

In a picoammeter or electrometer ammeter, note that ZERO CHECK and ZERO CORRECT functions are used to correct for internal voltage offsets. SUPPRESS or REL controls are used to correct for external current offsets.

For optimum accuracy, zero the instrument on the range to be used for measurement.

Generated Currents

Any extraneous generated currents in the test system will add to the desired current, causing errors. Currents can be internally generated, as in the case of instrument input offset current, or they can come from external sources such as insulators and cables. **Figure 5** summarizes the magnitudes of a number of generated currents.

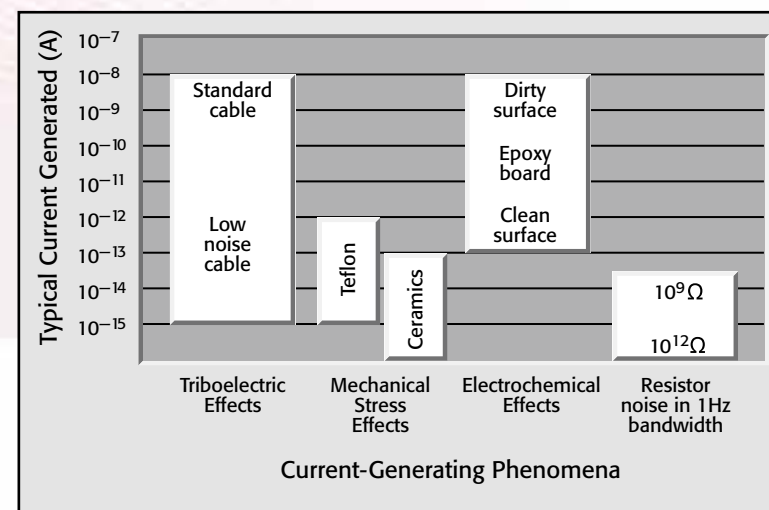

Figure 5: Typical Magnitudes of Generated Currents

Offset Currents

Offset currents can be generated within an instrument (input offset current) or can be generated from external circuitry (external offset current).

Input Offset Current

The ideal ammeter should read zero when its input terminals are left open. Practical ammeters, however, do have some small current that flows when the input is open. This current is known as the input offset current, and it's caused by bias currents of active devices as well as by leakage currents through insulators within the instrument. Offset currents generated within picoammeters, electrometers, and SMUs are included in the instrument's specifications. As shown in **Figure 6**, the

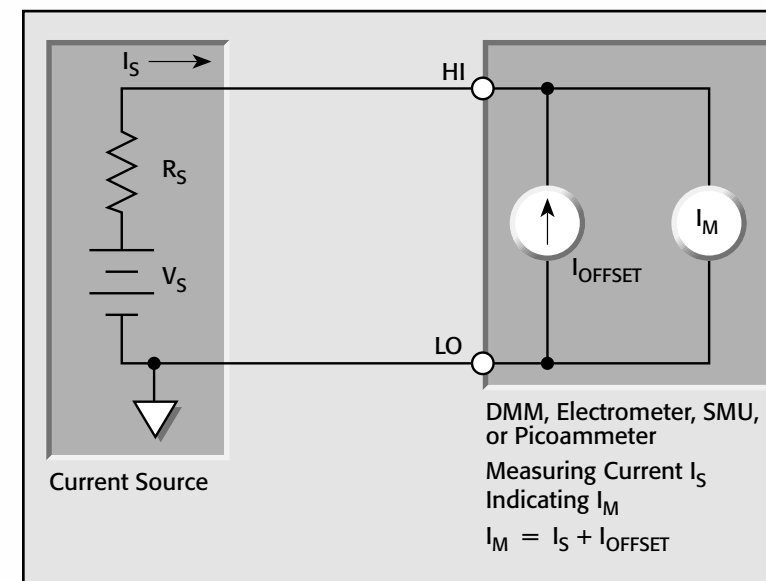

Figure 6: Effects of Input Offset Current on Current Measurement Accuracy

input offset current adds to the measured current so the meter measures the sum of the two currents:

$$I_M = I_S + I_{\text{OFFSET}}$$

Input offset current can be determined by capping the input connector and selecting the lowest current range. Allow about five minutes for the instrument to settle, then take a reading. This value should be within the instrument's specification.

If an instrument has current suppression, the input offset current can be partially nulled by enabling the current suppress function with the input terminals disconnected and ZERO CHECK open.

Another way to subtract the input offset current from measurements is to use the relative (REL or zero) function of the ammeter. With the input open-circuited, allow the reading to settle and then enable the REL function. Once the REL value is established, subsequent readings will be the difference between the actual input value and the REL value.

Introduction.....	2
Low Current Measurements	
Measurement Circuit.....	2
Leakage Currents and Guarding.....	3
Noise and Source Resistance.....	3
Zero Drift.....	4
Generated Currents.....	4
Overload Protection.....	6
AC Interference and Damping.....	6
Using a Coulombmeter to Measure Low Current.....	7
High Resistance Measurements	
Constant-Voltage Method.....	8
Constant-Current Method.....	8
Guarding.....	9
Settling Time.....	10
Low-I Application: Avalanche Photodiode Reverse Bias Current Measurements.....	11
High-R Application: Voltage Coefficient Testing of High Ohmic Value Resistors.....	12
Selector Guide.....	13
Glossary.....	14

Low Current Measurements (continued)

External Offset Current

External offset currents can be generated by ionic contamination in the insulators connected to the ammeter. Offset currents can also be generated externally from such sources as triboelectric and piezoelectric effects. As shown in **Figure 7**, the external offset current also adds to the source current, and the meter again measures the sum of the two.

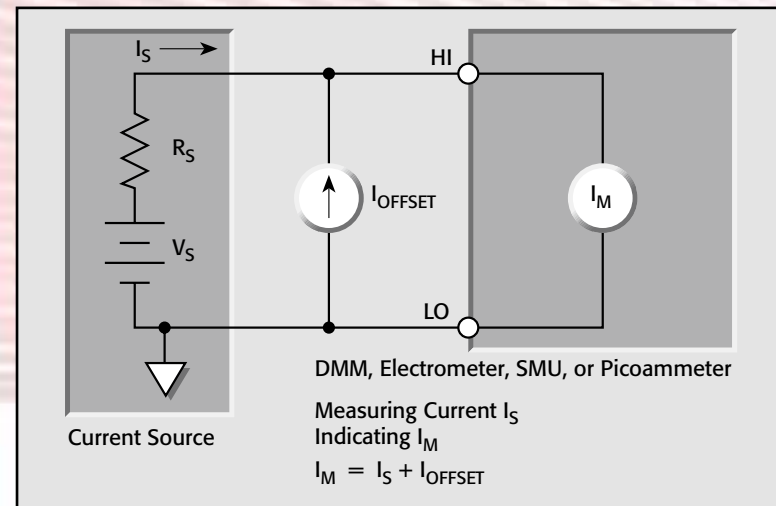

Figure 7: Effects of External Offset Current on Current Measurement Accuracy

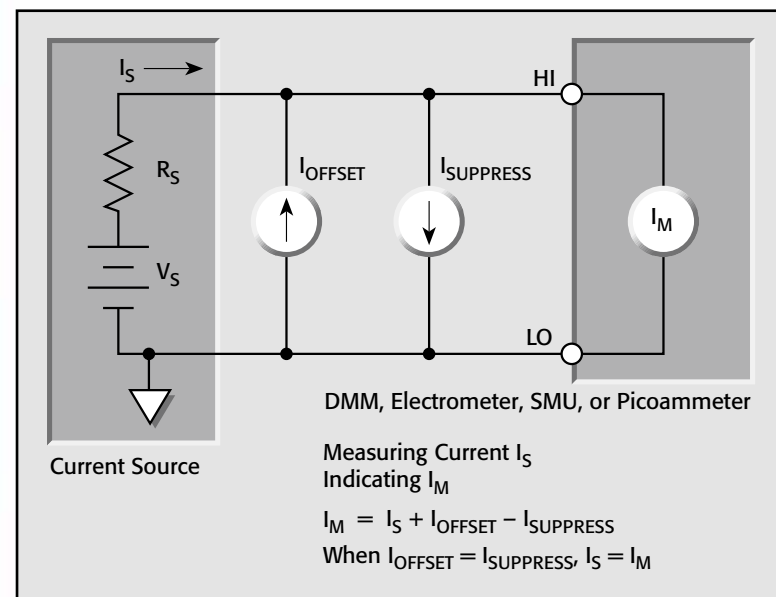

Figure 8: Using External Current Source to Suppress Offset Current

External offset currents can be suppressed with the current suppression feature (if available) of the instrument or they can be nulled by using a suitably stable and quiet external current source, as shown in **Figure 8**. With this arrangement, the current measured by the meter is:

$$I_M = I_S + I_{\text{OFFSET}} - I_{\text{SUPPRESS}}$$

Assuming I_{OFFSET} and I_{SUPPRESS} are equal in magnitude but opposite in polarity,

$$I_M = I_S$$

The advantage of using an external current source is that I_{OFFSET} can be as large or larger than the full-range value, and only $I_{\text{OFFSET}} - I_{\text{SUPPRESS}}$ need be small.

Triboelectric Effects

Triboelectric currents are generated by charges created between a conductor and an insulator due to friction. Here, free electrons rub off the conductor and create a charge imbalance that causes the current flow. A typical example would be electrical currents generated by insulators and conductors rubbing together in a coaxial cable, as shown in **Figure 9**.

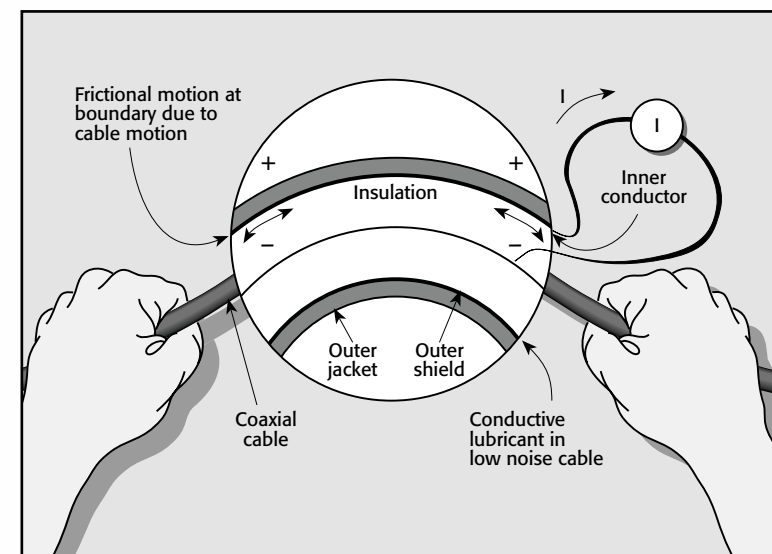

Figure 9: Triboelectric Effect

“Low noise” cable greatly reduces this effect. It typically uses an inner insulator of polyethylene coated with graphite underneath the outer shield. The graphite provides lubrication and a conducting equipotential cylinder to equalize charges and minimize charge generated by frictional effects of cable movement. However, even low noise cable creates some noise when subjected to vibration and expansion or contraction, so all connections should be kept short, away from temperature changes (which would create thermal expansion forces), and preferably supported by taping or tying the cable to a non-vibrating surface such as a wall, bench, or other rigid structure.

Piezoelectric and Stored Charge Effects

Piezoelectric currents are generated when mechanical stress is applied to certain crystalline materials when used for insulated terminals and interconnecting hardware. In some plastics, pockets of stored charge cause the material to behave in a manner similar to piezoelectric materials. An example of a terminal with a piezoelectric insulator is shown in **Figure 10**. To minimize the current due to this effect, it’s important to remove mechanical stresses from the insulator and use insulating materials with minimal piezoelectric and stored charge effects.

This effect is independent of the capacitance change between the plate and terminals. Charges are moved around, resulting in current flow. In practice, it may be quite difficult to distinguish stored charge effects (in

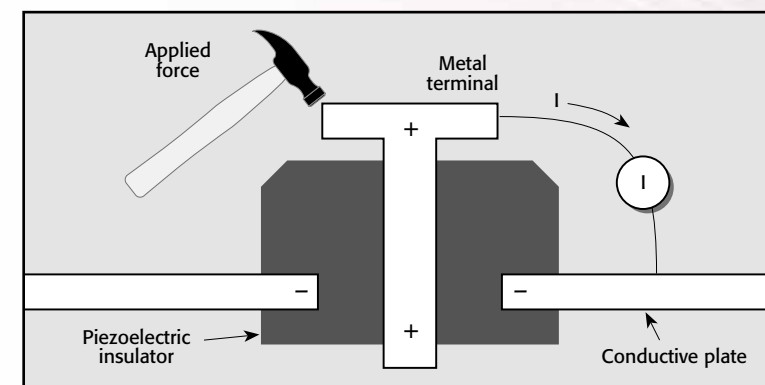

Figure 10: Piezoelectric Effect

- Introduction..... 2
- Low Current Measurements
 - Measurement Circuit 2
 - Leakage Currents and Guarding 3
 - Noise and Source Resistance 3
 - Zero Drift..... 4
 - Generated Currents 4
 - Overload Protection 6
 - AC Interference and Damping 6
 - Using a Coulombmeter to Measure Low Current..... 7
- High Resistance Measurements
 - Constant-Voltage Method..... 8
 - Constant-Current Method 8
 - Guarding..... 9
 - Settling Time 10
- Low-I Application: Avalanche Photodiode Reverse Bias Current Measurements..... 11
- High-R Application: Voltage Coefficient Testing of High Ohmic Value Resistors..... 12
- Selector Guide 13
- Glossary 14

Low Current Measurements (continued)

insulators) from piezoelectric effects. Regardless of the phenomenon involved, it's important to choose good insulating materials and make connecting structures as rigid as possible.

Contamination and Humidity

Error currents also arise from electrochemical effects when ionic chemicals create weak batteries between two conductors on a circuit board. For example, commonly used epoxy printed circuit boards, when not thoroughly cleaned of etching solution, flux or other contamination, can generate currents of a few nanoamps between conductors (see **Figure 11**).

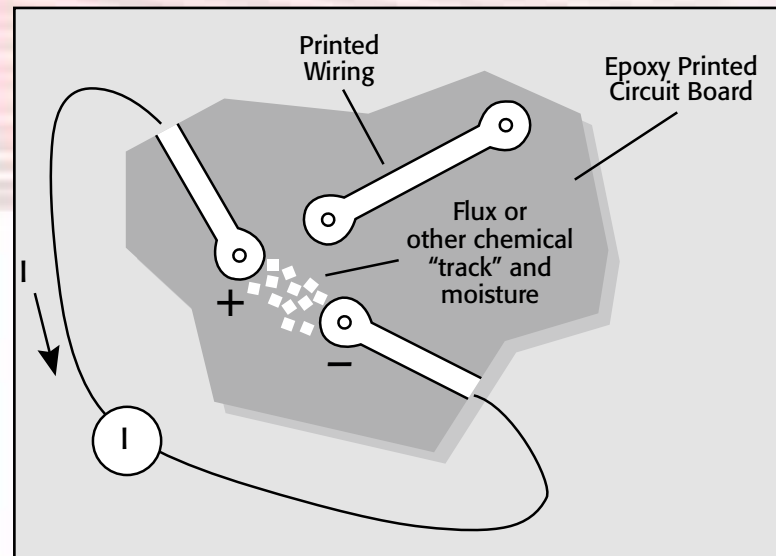

Figure 11: Electrochemical Effects

Insulation resistance can be dramatically reduced by high humidity or ionic contamination. High humidity conditions occur with condensation or water absorption, while ionic contamination may be the result of body oils, salts, or solder flux.

While the primary result of these contaminants is the reduction of insulation resistance, the combination of both high humidity and ionic contamination can form a conductive path, or they may even act as an electrochemical cell with high series resistance. A cell formed in this manner can source picoamps or nanoamps

of current for long periods of time. To avoid the effects of contamination and humidity, select insulators that resist water absorption, and keep humidity to moderate levels. Also, be sure all insulators are kept clean and free of contamination.

If insulators become contaminated, apply a cleaning agent such as methanol to all interconnecting circuitry. It's important to flush away all contaminants once they're dissolved in the solvent, so they won't be redeposited. Use only very pure solvents for cleaning; lower grades may contain contaminants that leave an electrochemical film.

Dielectric Absorption

Dielectric absorption in an insulator can occur when a voltage across that insulator causes positive and negative charges within the insulator to polarize because various polar molecules relax at different rates. When the voltage is removed, the separated charges generate a decaying current through circuits connected to the insulator as they recombine.

To minimize the effects of dielectric absorption on current measurements, avoid applying voltages greater than a few volts to insulators being used for sensitive current measurements. In cases where this practice is unavoidable, it may take minutes or even hours in some cases for the current caused by dielectric absorption to dissipate.

Overload Protection

Electrometers, picoammeters, and SMUs may be damaged if excessive voltage is applied to the input. Most instruments have a specification for the maximum allowable voltage input. In some applications, this maximum voltage may be unavoidably exceeded. Some of these applications may include leakage current of capacitors, reverse diode leakage, or insulation resistance of cables or films. If the component or material breaks down, all the voltage would be applied to the ammeter's input, possibly destroying it. In these cases, additional overload protection is required to avoid damaging the input circuitry of the instrument.

AC Interference and Damping

When measuring low current, electrostatic shielding is the most common way to reduce noise due to AC interference. However, in some cases, shielding the device under test or the connecting cabling isn't practical. For these applications, a variable damping control may reduce the AC pickup enough to make meaningful measurements. A damping circuit is a type of low pass filter that reduces the electrometer's AC response so the low DC current can be measured accurately. The damping circuit may already be built into the electrometer or may be an external circuit. Refer to the instrument's instruction manual for information on a particular electrometer's internal damping feature. However, it may be necessary to increase the damping with an external circuit.

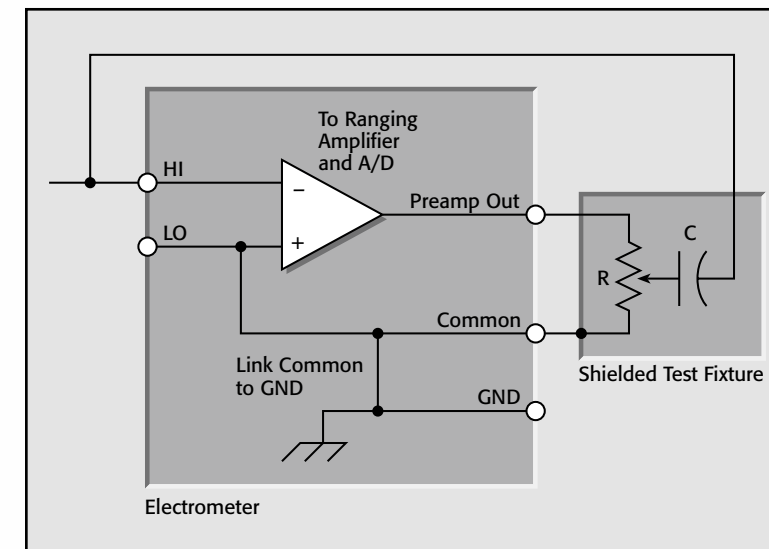

Figure 12: External Damping Circuit

Figure 12 illustrates an example of an external damping circuit. This circuit consists of a low leakage polystyrene or polyester capacitor (C) and a potentiometer (R). The potentiometer is connected between the preamp output and the common (or LO) terminal of the ammeter. The capacitor is connected between the HI input terminal of the ammeter and the moving arm of the potentiometer. The value of the capacitor depends on the current range of the ammeter. Higher ranges require the use of higher

Introduction.....	2
Low Current Measurements	
Measurement Circuit	2
Leakage Currents and Guarding	3
Noise and Source Resistance	3
Zero Drift.....	4
Generated Currents	4
Overload Protection.....	6
AC Interference and Damping	6
Using a Coulombmeter to Measure Low Current.....	7
High Resistance Measurements	
Constant-Voltage Method.....	8
Constant-Current Method.....	8
Guarding.....	9
Settling Time	10
Low-I Application: Avalanche Photodiode Reverse Bias Current Measurements.....	11
High-R Application: Voltage Coefficient Testing of High Ohmic Value Resistors.....	12
Selector Guide	13
Glossary	14

Want to Explore Further?

Featured Resources



- **Improving Low Current Measurements on Nanoelectronic and Molecular Electronic Devices**



- **Techniques for Accurate Nanotech Electrical Measurements**

- **Instrument Techniques that Reduce Effects of External Error Sources**

- **Counting Electrons: How to Measure Currents in the Attoampere Range**

- **New Instruments Can Lock Out Lock-ins**

Ask Us Your Application or Product Question.

Low Current Measurements (continued)

magnitude capacitors. However, typical values of the capacitor are in the range of hundreds of picofarads. The value of the potentiometer should be chosen to be high enough ($>50k\Omega$) to avoid loading the preamp output but still reduce noise effectively.

Some experimentation will be needed to choose the best values for the capacitor and the resistance. Connect an oscilloscope to the analog output and observe the AC waveform on the scope. Adjust the potentiometer to make the AC signal as small as possible. If the noise can't be suppressed enough with the potentiometer, use a bigger capacitor. The damping circuit should be built into a shielded enclosure.

Using a Coulombmeter to Measure Low Current

In most cases, an ammeter or picoammeter is used to measure current. However, for femtoamp-level currents, it may be better to use the coulombs function of an electrometer to measure the change in charge over time, then use those charge measurements to determine the current.

Charge is difficult to measure directly; it must be related to an easily measured quantity. One commonly used method of making this type of measurement is to measure the voltage across a capacitor of known value. The charge is related to capacitor voltage as follows:

$$Q = CV$$

where: Q = capacitor charge (coulombs)

C = capacitor value (farads)

V = voltage across capacitor (volts)

Once the rate of change in charge is known, the current can easily be determined from the charge measurement. The instantaneous current (i) is simply:

$$i = \frac{dQ}{dt}$$

while the long-term average current is defined as:

$$I_{AVG} = \frac{\Delta Q}{\Delta t}$$

Thus, we see that charge can be measured and current can be determined simply by making a series of voltage measurements.

ADVANTAGES OF USING A COULOMBMETER TO MEASURE CURRENT

There are several advantages to using a coulombmeter instead of an ammeter for measuring current in certain situations:

- **Lower Current Noise:** The ammeter uses a feedback resistor, which will have significant Johnson noise. For charge measurement, this resistor is replaced by a capacitor, which theoretically has no Johnson noise. Consequently, the charge method of current measurement results in lower noise than measuring currents directly with a feedback ammeter. Thus, the charge method is preferable when current noise performance less than 1fA p-p is required.
- **Faster Settling Times:** The speed of a feedback ammeter is limited by the time constant of its feedback circuit ($R_F C_F$). For example, for feedback resistances greater than $10G\Omega$, stray capacitance limits response times to tens of milliseconds. In contrast, a feedback integrator will respond immediately and is limited only by the speed of the operational amplifier.
- **Random Pulses Can Be Integrated:** The average charge transferred per unit time of random pulse trains can be evaluated by integrating the current pulse train for a given period of time. The average current amplitudes can then be expressed as the total charge divided by the time period involved in the measurement. This technique is especially useful when averaging very small, unsteady currents. If the duty cycle is known, the pulse height can also be determined.
- **The Noise Effects of Input Shunt Capacitance are Minimized:** Noise gain is mainly determined by C_{IN}/C_F , and C_F is much larger in a coulombmeter than in an ammeter, so much larger input capacitance values can be tolerated. This characteristic is beneficial when measuring from high capacitance sources or when long connecting cables are used.

Introduction.....	2
Low Current Measurements	
Measurement Circuit	2
Leakage Currents and Guarding	3
Noise and Source Resistance	3
Zero Drift.....	4
Generated Currents	4
Overload Protection.....	6
AC Interference and Damping	6
Using a Coulombmeter to Measure Low Current.....	7
High Resistance Measurements	
Constant-Voltage Method.....	8
Constant-Current Method.....	8
Guarding.....	9
Settling Time	10
Low-I Application: Avalanche Photodiode Reverse Bias Current Measurements.....	11
High-R Application: Voltage Coefficient Testing of High Ohmic Value Resistors.....	12
Selector Guide	13
Glossary	14

Want to Explore Further?

Additional Resources

- [Solutions for Production Testing of Connectors](#)
- [Diode Production Testing with Series 2400 SourceMeter® Instruments](#)
- [Current Switching Demands Special Attention to Ensure Test System Accuracy](#)
- [Making Ultra-Low Current Measurements with the Low-Noise Model 4200-SCS Semiconductor Characterization System](#)
- [Problem: Noise in Low Current Measurements](#)

Ask Us Your Application or Product Question.

High Resistance Measurements

When resistances greater than $1\text{G}\Omega$ must be measured, an electrometer, SMU, or picoammeter/voltage source are usually required. An electrometer may measure high resistance by either the constant-voltage or the constant-current method. Some electrometers allow the user to choose either method. The constant-voltage method uses an ammeter and a voltage source, while the constant-current method uses an electrometer voltmeter and a current source.

Constant-Voltage Method

To make high resistance measurements using the constant-voltage method, an instrument that can measure low current and a constant DC voltage source are required. Some electrometers and picoammeters have voltage sources built into the instrument and automatically can calculate the unknown resistance.

The basic configuration of the constant-voltage method using an electrometer or picoammeter is shown in **Figure 13a**. As shown in **Figure 13b**, an SMU can also be used

for making high resistance measurements using the constant voltage method.

In this method, a constant voltage source (V) is placed in series with the unknown resistor (R) and an ammeter (I_M). Since the voltage drop across the ammeter is negligible, essentially all the test voltage appears across R . The resulting current is measured by the ammeter and the resistance is calculated using Ohm's Law ($R=V/I$).

High resistance is often a function of the applied voltage, which makes the constant-voltage method preferable to the constant-current method. By testing at selected voltages, a resistance vs. voltage curve can be developed and a "voltage coefficient of resistance" can be determined.

Some of the applications that use this method include testing two-terminal high resistance devices, measuring insulation resistance, and determining the volume and surface resistivity of insulating materials.

The constant-voltage method requires measuring low current, so all the techniques and error sources described previously in the Low Current Measurements section apply to this method. The two most common error sources when measuring high resistance are electrostatic interference (which can be minimized by shielding the high impedance circuitry) and leakage current (which can be controlled by guarding).

Constant-Current Method

High resistance measurements using the constant-current method may be made using either an electrometer voltmeter and current source or just an electrometer ohmmeter. An SMU that has a voltmeter with high input impedance and low current source ranges may also be used. Using the electrometer voltmeter with a separate current source or an SMU allows the user to make a four-wire measurement and to control the amount of current through the sample. The electrometer ohmmeter makes a two-wire resistance measurement at a specific test current, depending on the measurement range.

Using the Electrometer Voltmeter and an External Current Source

The basic configuration for the constant-current method is shown in **Figure 14**. Current from the source (I) flows through the unknown resistance (R) and the voltage drop is measured by the electrometer voltmeter (V). Using this method, resistances up to about $10^{12}\Omega$ can be measured. Even though the basic procedure seems simple enough, some precautionary measures must be taken. The input impedance of the voltmeter must be high enough compared with a source resistance to keep the loading error within acceptable limits. Typically, the input impedance of an electrometer voltmeter is about $10^{14}\Omega$. Also, the output

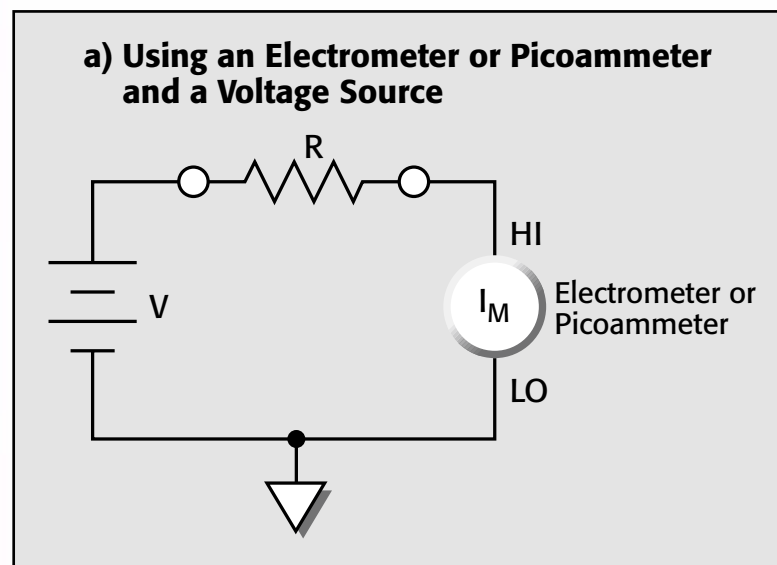

Figure 13a: Constant-Voltage Method for Measuring High Resistance with an Electrometer or Picoammeter

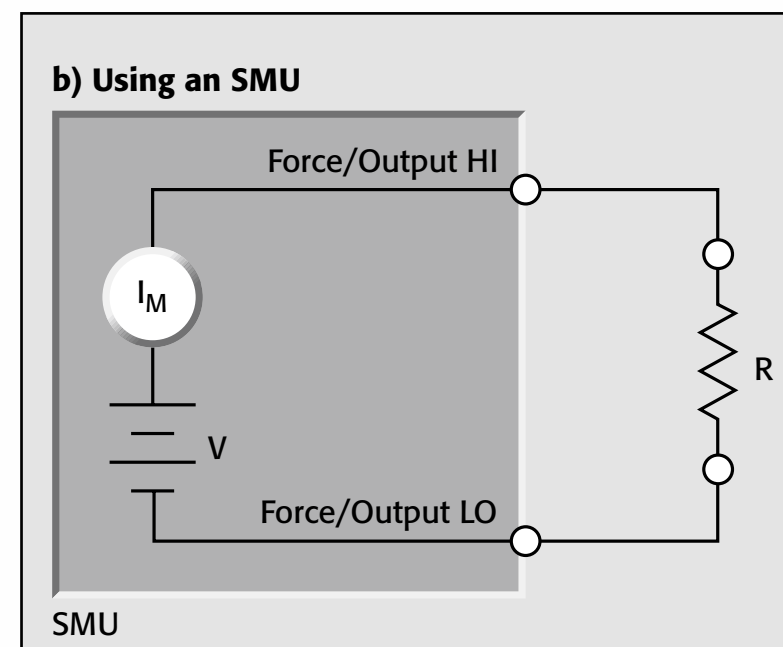

Figure 13b: Constant-Voltage Method for Measuring High Resistance with an SMU

- Introduction..... 2
- Low Current Measurements
 - Measurement Circuit 2
 - Leakage Currents and Guarding 3
 - Noise and Source Resistance 3
 - Zero Drift.....4
 - Generated Currents 4
 - Overload Protection..... 6
 - AC Interference and Damping 6
 - Using a Coulombmeter to Measure Low Current..... 7
- High Resistance Measurements
 - Constant-Voltage Method..... 8
 - Constant-Current Method..... 8
 - Guarding..... 9
 - Settling Time 10
- Low-I Application: Avalanche Photodiode Reverse Bias Current Measurements..... 11
- High-R Application: Voltage Coefficient Testing of High Ohmic Value Resistors..... 12
- Selector Guide 13
- Glossary 14

Ask Us Your Application or Product Question.

High Resistance Measurements (continued)

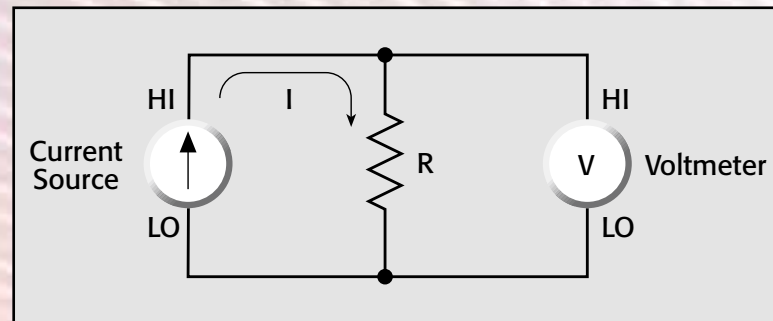

Figure 14: Constant-Current Method Using a Separate Current Source and Voltmeter

resistance of the current source must be much greater than the unknown resistance for the measurement to be linear. The voltage across the sample depends upon the sample resistance, which makes it difficult to account for voltage coefficient when using the constant-current method. If voltage coefficient is a concern, it's best to use the constant-voltage method. The electrometer voltmeter and a separate current source are used when determining high resistivity of semiconductor materials using the four-point probe or van der Pauw technique.

Using an SMU in the Source I, Measure V Mode

An SMU can measure high resistance in the source current/measure voltage mode by using either a two-wire (local

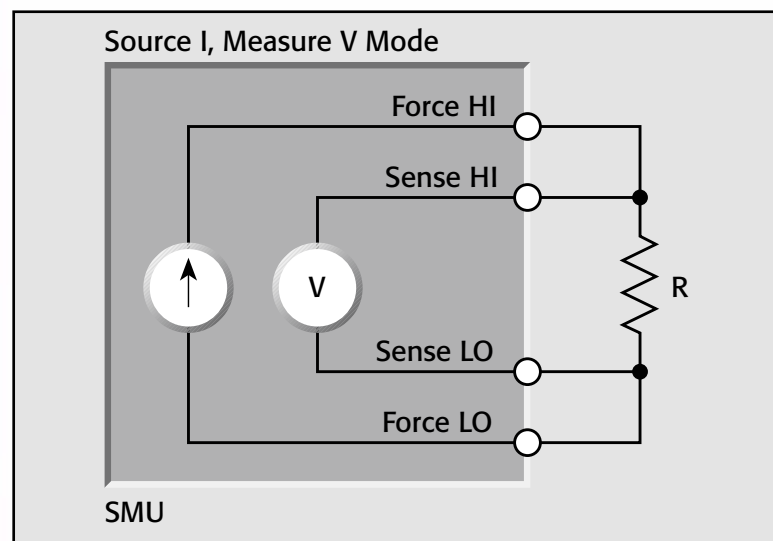

Figure 15: Using the SMU in the Four-Wire Mode to Measure High Resistance

sense) or four-wire (remote sense) method. **Figure 15** illustrates an SMU in four-wire mode. The four-wire method is used to eliminate contact and lead resistance, which is especially important when measuring resistivity of semiconductor materials. These measurements usually involve measuring low voltages. The resistance of the metal probe to semiconductor contact can be quite high. When using remote sense, the voltage difference between high force and high sense and between low force and low sense is usually limited to a specified value. Exceeding this voltage difference can result in erratic measurements. Check the instruction manual of your SMU for further information on this limitation.

In addition to the voltage drop limitation, some SMUs have automatic remote sensing resistors located between the HI Force and HI Sense terminals and between the LO Force and LO Sense terminals. This may further limit the use of a single SMU in remote mode for certain applications, such as semiconductor resistivity. If this is the case, use the SMU as a current source in the two-wire mode, and use a separate voltmeter(s) to measure the voltage difference. See Section 4.4.3 of Keithley's *Low Level Measurements Handbook* for further information.

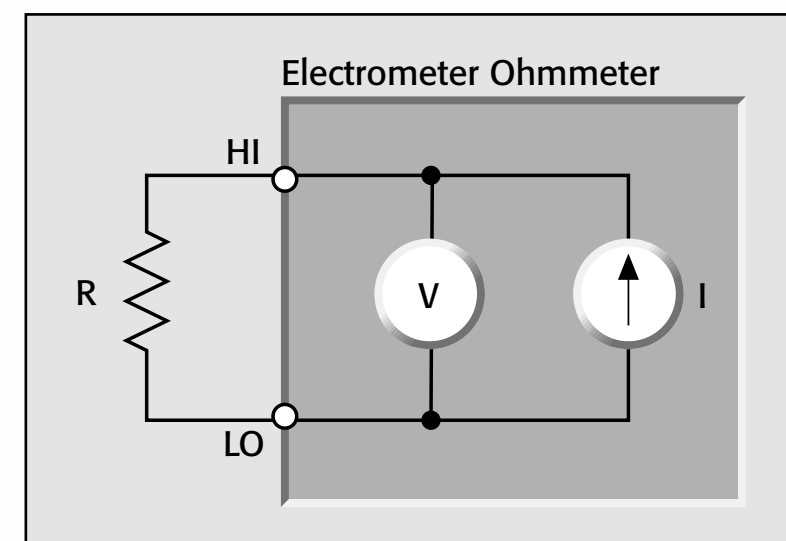

Figure 16: Using the SMU in the Four-Wire Mode to Measure High Resistance

Using the Electrometer Ohmmeter

When using the electrometer ohmmeter, measurement accuracy can be affected by a variety of factors. **Figure 16** shows the electrometer ohmmeter measuring a resistance (R). The ohmmeter uses an internal current source and electrometer voltmeter to make the measurement. It automatically calculates and displays the measured resistance. Notice that this is a two-wire resistance measurement compared to using the electrometer voltmeter and external current source, which can make a four-wire measurement. This is because the current source is internally connected to the voltmeter and cannot be used separately.

Guarding

As with current measurements, guarding high resistance test connections can significantly reduce the effects of cable leakage resistance and improve measurement accuracy. The loading effects of cable resistance (and other leakage resistances) can be virtually eliminated by driving the cable shield with a unity-gain amplifier, as shown in **Figure 17**. Since the voltage across R_L is essentially zero, all the test current (I_R) now flows through R_S , and the source resistance value can be accurately determined. The

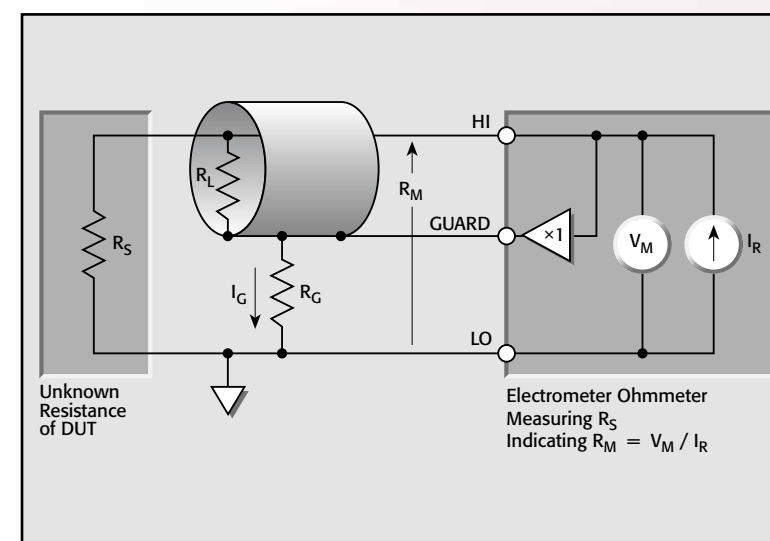

Figure 17: Guarding Cable Shield to Eliminate Leakage Resistance

- Introduction..... 2
- Low Current Measurements
 - Measurement Circuit 2
 - Leakage Currents and Guarding 3
 - Noise and Source Resistance 3
 - Zero Drift..... 4
 - Generated Currents 4
 - Overload Protection 6
 - AC Interference and Damping 6
 - Using a Coulombmeter to Measure Low Current..... 7
- High Resistance Measurements
 - Constant-Voltage Method..... 8
 - Constant-Current Method..... 8
 - Guarding..... 9
 - Settling Time 10
- Low-I Application: Avalanche Photodiode Reverse Bias Current Measurements..... 11
- High-R Application: Voltage Coefficient Testing of High Ohmic Value Resistors..... 12
- Selector Guide 13
- Glossary 14

Want to Explore Further?

Featured Resources

- **Improving the Repeatability of Ultra-High Resistance and Resistivity Measurements**
- **Instrumentation and Techniques for Measuring High Resistivity and Hall Voltage of Semiconducting Materials**
- **Volume and Surface Resistivity Measurements of Insulating Materials**

Ask Us Your Application or Product Question.

High Resistance Measurements (continued)

leakage current (I_G) through the cable-to-ground leakage path (R_G) may be considerable, but that current is supplied by the low impedance output of the $\times 1$ amplifier rather than by the current source (I_R).

Settling Time

The settling time of the circuit is particularly important when making high resistance measurements. The settling time of the measurement is affected by the shunt capacitance, which is due to the connecting cable, test fixturing, and the DUT. As shown in **Figure 18**, the shunt capacitance (C_{SHUNT}) must be charged to the test voltage by the current (I_S). The time period required for charging the capacitor is determined by the RC time constant (one time constant, $\tau = R_S C_{SHUNT}$), and the familiar exponential curve of **Figure 19** results. Thus, it becomes necessary to wait four or five time constants to achieve an accurate reading. When measuring very high resistance values, the settling time can range up to minutes, depending on the amount of shunt capacitance in the test system. For example, if C_{SHUNT} is only 10pF, a test resistance of $1T\Omega$ will result in a time constant of 10 seconds. Thus, a settling time of 50 seconds would be required for the reading to settle to within 1% of final value.

In order to minimize settling times when measuring high resistance values, keep shunt capacitance in the system to an absolute minimum by keeping connecting cables as short as possible. Also, guarding may be used to decrease settling times substantially. Finally, the source voltage, measure current method of resistance measurement is generally faster because of reduced settling times.

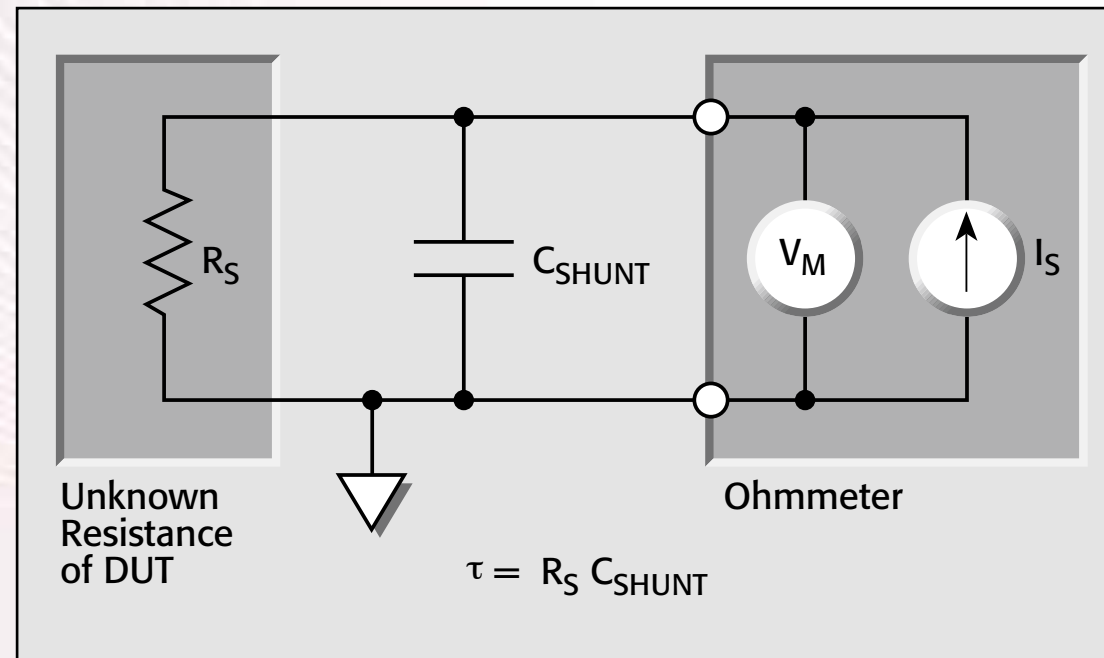

Figure 18: Settling Time is the Result of $R_S C_{SHUNT}$ Time Constant

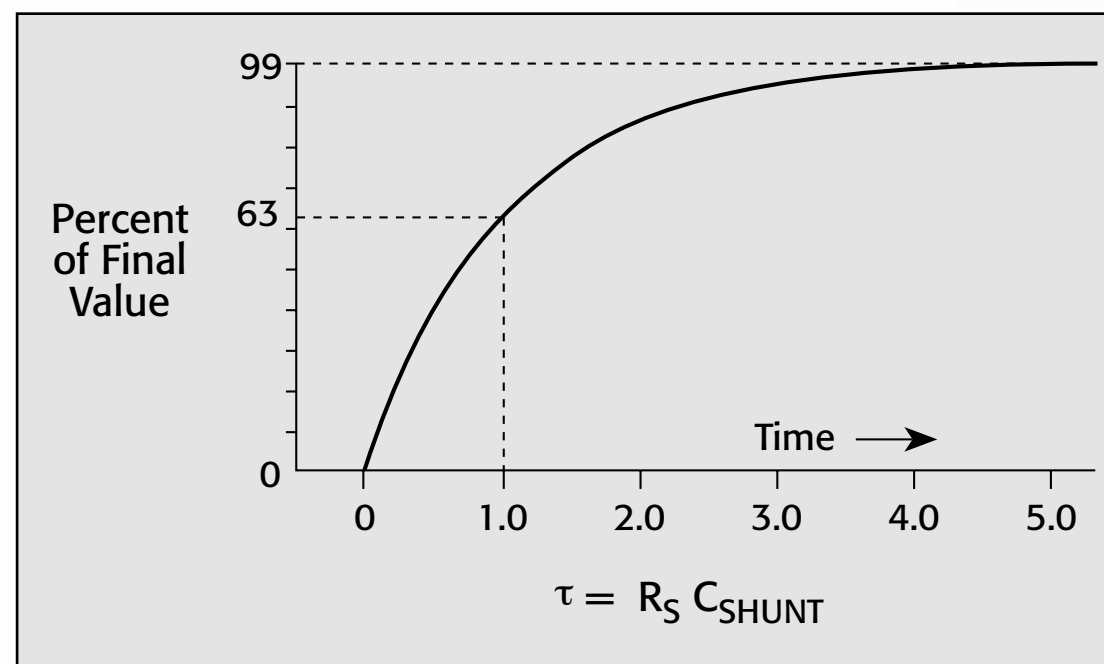

Figure 19: Exponential Settling Time Caused by Time Constant of Shunt Capacitance and Source Resistance

Introduction.....	2
Low Current Measurements	
Measurement Circuit	2
Leakage Currents and Guarding	3
Noise and Source Resistance	3
Zero Drift.....	4
Generated Currents	4
Overload Protection.....	6
AC Interference and Damping	6
Using a Coulombmeter to Measure Low Current.....	7
High Resistance Measurements	
Constant-Voltage Method.....	8
Constant-Current Method.....	8
Guarding.....	9
Settling Time	10
Low-I Application: Avalanche Photodiode Reverse Bias Current Measurements.....	11
High-R Application: Voltage Coefficient Testing of High Ohmic Value Resistors.....	12
Selector Guide	13
Glossary	14

Want to Explore Further?

Additional Resources

- **Problem: Noisy Readings in High Resistance Measurements**
- **Obtaining More Accurate Resistance Measurements Using the 6-Wire Ohms Measurement Technique**

Ask Us Your Application or Product Question.

Low-I Application: Avalanche Photodiode Reverse Bias Current Measurements

An avalanche photodiode (APD) is a high sensitivity, high speed photodiode that has an internal gain mechanism activated by applying a reverse voltage. The gain of the APD can be controlled by the magnitude of the reverse bias voltage. A larger reverse bias voltage results in a larger gain. APDs are operated with an electric field strength such that an avalanche multiplication of photocurrent occurs similar to a chain reaction. APDs are used in a variety of applications requiring high sensitivity to light such as fiberoptic communications and scintillation detectors.

Measuring the reverse bias current of an APD requires an instrument that can measure current over a wide range as well as output a voltage sweep. Because of these requirements, instruments such as the Model 6487 Picoammeter/Voltage Source or the Model 6430 Sub-Femtoamp Remote SourceMeter instrument are ideal for these measurements.

Figure 20 shows a Model 6430 connected to a photodiode. The photodiode is placed in an electrically shielded dark box. To shield the sensitive current measurements from electrostatic interference, connect the box to the LO terminal of the Model 6430.

Figure 21 shows a current vs. reverse voltage sweep of an InGaAs APD, generated by the Model 6430 SourceMeter Instrument. Note the wide range of current measurements. The avalanche region becomes more pronounced with increasing light. The breakdown voltage will cause the current to flow freely since electron-hole pairs will form without the need for light striking the diode to generate current.

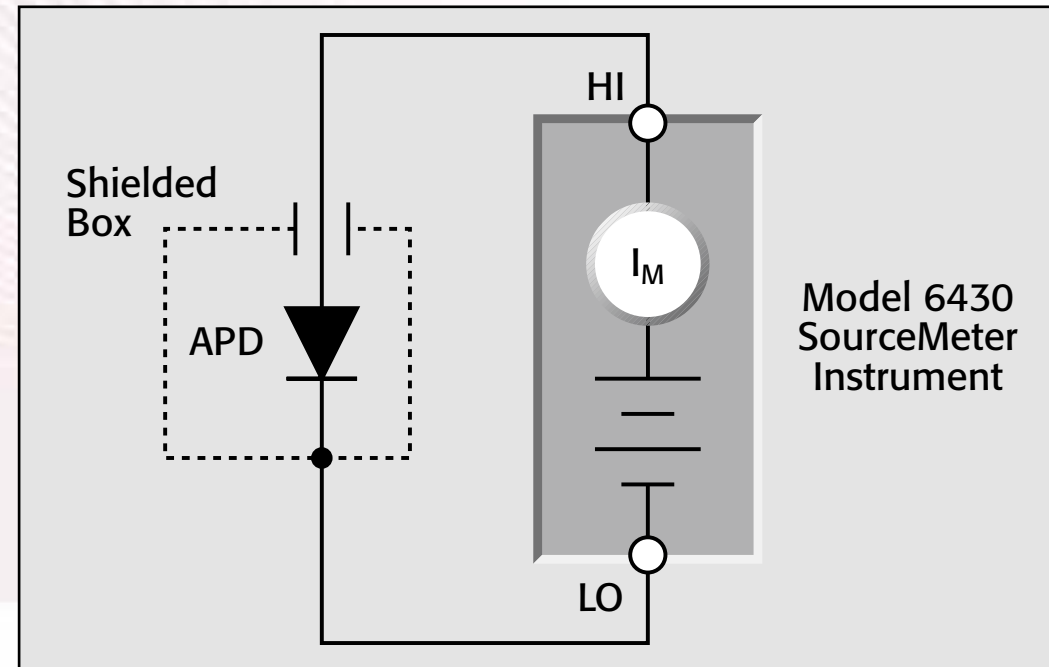

Figure 20: APD Connected to a Model 6430 Sub-Femtoamp Remote SourceMeter Instrument

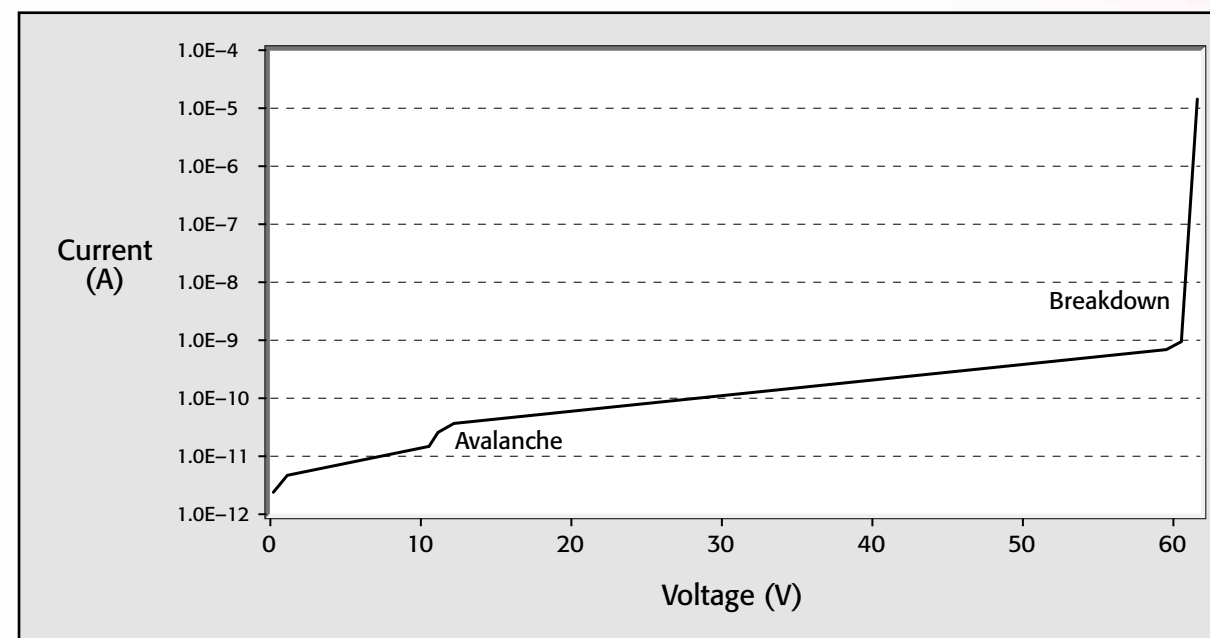

Figure 21: Current vs. Reverse Voltage Sweep of an InGaAs APD

- Introduction..... 2
- Low Current Measurements
 - Measurement Circuit 2
 - Leakage Currents and Guarding..... 3
 - Noise and Source Resistance 3
 - Zero Drift.....4
 - Generated Currents 4
 - Overload Protection..... 6
 - AC Interference and Damping 6
 - Using a Coulombmeter to Measure Low Current..... 7
- High Resistance Measurements
 - Constant-Voltage Method..... 8
 - Constant-Current Method..... 8
 - Guarding..... 9
 - Settling Time 10
- Low-I Application: Avalanche Photodiode Reverse Bias Current Measurements..... 11
- High-R Application: Voltage Coefficient Testing of High Ohmic Value Resistors..... 12
- Selector Guide 13
- Glossary 14

Want to Explore Further?

Featured Resources



- **4H-SiC UV Photo Detectors with Large Area and Very High Specific Detectivity**
- **Problem: Errors in Low Current Measurements**

Additional Resources

- **High Accuracy Picoammeters for Low Current/High Resistance Applications**

Ask Us Your Application or Product Question.

High-R Application: Voltage Coefficient Testing of High Ohmic Value Resistors

High ohmic value resistors may exhibit a significant change in resistance with a change in applied voltage. This effect is known as the voltage coefficient. The voltage coefficient is the percent change in resistance per unit change in applied voltage and is defined as follows:

$$\text{Voltage Coefficient (\%/V)} = \frac{(R_2 - R_1)}{R_1} \times \frac{1}{(V_2 - V_1)} \times 100$$

Alternately, the voltage coefficient may be expressed in ppm as follows:

$$\text{Voltage Coefficient (ppm/V)} = \frac{(R_2 - R_1)}{R_1} \times \frac{1}{(V_2 - V_1)} \times 10^6$$

where: R_1 = resistance calculated with first applied voltage (V_1).

R_2 = resistance calculated with second applied voltage (V_2).

$$V_2 > V_1$$

A typical voltage coefficient for a 10G Ω resistor can be about -0.008%/V or -80ppm/V. Thus, if a high resistance is required in a measurement circuit, the error analysis must account for the error due to the voltage coefficient of the resistor, in addition to all other time and temperature error factors.

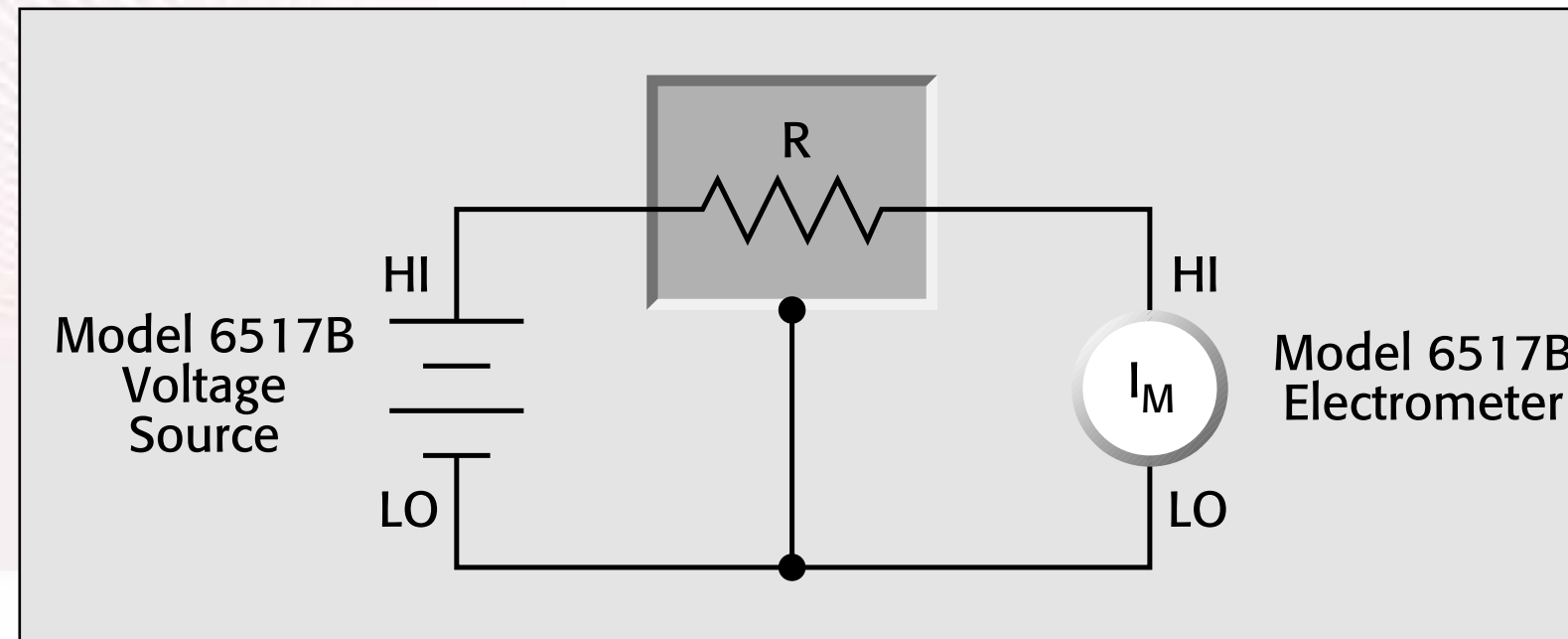

Figure 22: Connecting the Model 6517B Electrometer for Voltage Coefficient Testing

Using the Model 6517B to Determine Voltage Coefficient

Measuring the voltage coefficient of a high resistance requires sourcing a voltage and measuring a low current. An electrometer, such as the Model 6517B, is required to make this measurement. The Model 6517B has a built-in test sequence for determining voltage coefficient. This test makes resistance measurements at two different voltage levels, then calculates the voltage coefficient. The voltage coefficient is displayed as a percent change in resistance per volt.

Figure 22 is a typical test configuration for voltage coefficient measurements with the Model 6517B. To minimize noise and leakage resistance, the resistor should be placed in a shielded, guarded test fixture. Connect the shield of the test fixture to the LO of the electrometer and connect the LO of the electrometer to the LO of the source. Connect the HI terminal of the electrometer to one end of the resistor and the HI of the voltage source to the other end.

The resistor is first measured with test voltage V_1 , giving R_1 . Next, it is measured with test voltage V_2 (where V_2 is greater than V_1), giving R_2 . The voltage coefficient for the resistor is then calculated using the equation given previously.

- Introduction..... 2
- Low Current Measurements
 - Measurement Circuit 2
 - Leakage Currents and Guarding 3
 - Noise and Source Resistance 3
 - Zero Drift.....4
 - Generated Currents 4
 - Overload Protection..... 6
 - AC Interference and Damping 6
 - Using a Coulombmeter to Measure Low Current..... 7
- High Resistance Measurements
 - Constant-Voltage Method..... 8
 - Constant-Current Method..... 8
 - Guarding..... 9
 - Settling Time 10
- Low-I Application: Avalanche Photodiode Reverse Bias Current Measurements..... 11
- High-R Application: Voltage Coefficient Testing of High Ohmic Value Resistors..... 12
- Selector Guide 13
- Glossary 14

Want to Explore Further?

Featured Resources



- **High Voltage Component Production Testing with Two Model 2410 SourceMeter® Units**
- **Configuring a Discrete Resistor Verification Test System**

Additional Resources

- **Techniques for Reducing Resistance Measurement Uncertainty: DC Current Reversals vs. Classic Offset Compensation**

Ask Us Your Application or Product Question.

Selector Guide

	CURRENT AMPLIFIER	PICOAMMETERS			ELECTROMETERS		SOURCE-MEASURE UNIT
MODEL	428-PROG	6485	6487	2502	6514	6517B	6430
CURRENT MEASURE							
From ¹	1.2 fA	20 fA	20 fA	15 fA	<1 fA	<1 fA	400 aA
To	10 mA	20 mA	20 mA	20 mA	20 mA	20 mA	100 mA
VOLTAGE MEASURE							
From ²					10 μ V	10 μ V	10 μ V
To					200 V	200 V	200 V
RESISTANCE MEASURE⁴							
From ⁵			10 Ω		10 Ω	100 Ω	100 $\mu\Omega$
To ⁶			1 P Ω		200 G Ω	10 P Ω^3	10 P Ω^3
CHARGE MEASURE							
From ²					10 fC	10 fC	
To					20 μ C	2 μ C	
FEATURES							
Input Connection	BNC	BNC	3 Slot Triax	3 Slot Triax	3 Slot Triax	3 Slot Triax	3 Slot Triax
IEEE-488	•	•	•	•	•	•	•
RS-232		•	•	•	•	•	•
Guard					•	•	•
CE	•	•	•	•	•	•	•
Other	2 μ s rise time. 10 ¹¹ V/A gain.	5 $\frac{1}{2}$ digits. Autoranging. 1000 rdg/s.	5 $\frac{1}{2}$ digits. Built-in 500V source. Alternating voltage method for HI-R sweeps.	5 $\frac{1}{2}$ digits. Dual channel. Built-in 100V source per channel.	5 $\frac{1}{2}$ digits. Replaces Models 6512, 617-HIQ.	5 $\frac{1}{2}$ digits. Built-in \pm 1kV source. Temperature, RH measurements. Alternating polarity method for HI-R. Plug-in switch cards available. Replaces 6517A.	SourceMeter Instrument with Remote PreAmp to minimize cable noise.

	CURRENT SOURCES		VOLTAGE SOURCE	SOURCE-MEASURE UNITS	
MODEL	6220	6221	248	2635A	6430
Current Source	•	•		•	•
Voltage Source			•	•	•
Sink	•	•	•	•	•
CURRENT OUTPUT					
Accuracy ⁷	2 pA	2 pA DC 4 pA AC		2 pA	10 fA
Resolution ⁸	100 fA	100 fA (DC & AC)		20 fA	50 aA
Maximum	\pm 105 mA	\pm 105 mA		\pm 1.5 A DC and pulsed/10 A pulsed per channel	\pm 105 mA
VOLTAGE OUTPUT					
From			\pm 1.5 V	\pm 5 μ V	\pm 5 μ V
To			\pm 5000 V	\pm 202 V	\pm 210 V
POWER OUTPUT					
	11 W	11 W	25 W	30.3 V/channel	2.2 W
CURRENT LIMIT					
			5.25 mA	1 fA to 10 A	1 fA to 105 mA
VOLTAGE LIMIT					
	105 V	105 V	0 to 5000 V	1 μ V to 200V	0.2 mV to 210 V
ACCURACY (\pmSetting)					
I	0.05%	0.05%		0.03%	0.03%
V			0.01%	0.02%	0.02%
FEATURES					
Output Connector	3 Slot Triax	3 Slot Triax	SHV High Voltage Coax	Screw terminals, adapters for banana and triax	3 Slot Triax
Ethernet		•		•	
RS-232	•	•		•	•
IEEE-488	•	•	•	•	•
Memory	65,000 pt.	65,000 pt.		>100,000 rdgs/buffer	2500 pt.
Remote Sense				•	•
Current Source Guard	•	•		•	•
CE	•	•	•	•	•
Other	Controls 2182A for low-power resistance and I-V measurements.	AC and DC current source. ARB waveforms up to 100kHz. Controls 2182A like 6220, adds pulsed I-V.	Voltage monitor output. Programmable voltage limit.	Scalable to 64+ channels with TSP-Link® technology	

- Introduction..... 2
- Low Current Measurements
 - Measurement Circuit 2
 - Leakage Currents and Guarding 3
 - Noise and Source Resistance 3
 - Zero Drift..... 4
 - Generated Currents 4
 - Overload Protection 6
 - AC Interference and Damping 6
 - Using a Coulombmeter to Measure Low Current..... 7
- High Resistance Measurements
 - Constant-Voltage Method..... 8
 - Constant-Current Method..... 8
 - Guarding..... 9
 - Settling Time 10
- Low-I Application: Avalanche Photodiode Reverse Bias Current Measurements..... 11
- High-R Application: Voltage Coefficient Testing of High Ohmic Value Resistors..... 12
- Selector Guide 13
- Glossary 14

- NOTES**
1. Includes noise.
 2. Digital resolution limit. Noise may have to be added.
 3. P Ω (Petaohms) = 10¹⁵ Ω .
 4. Resistance is measured with the Model 237 using Source V/Measure I or Source I/Measure V, but not directly displayed.
 5. Lowest resistance measurable with better than 1% accuracy.
 6. Highest resistance measurable with better than 10% accuracy.
 7. Best absolute accuracy of source.
 8. Resolution for lowest range, smallest change in current that source can provide.

Ask Us Your Application or Product Question.

Glossary

ABSOLUTE ACCURACY. A measure of the closeness of agreement of an instrument reading compared to that of a primary standard having absolute traceability to a standard sanctioned by a recognized standards organization. Accuracy is often separated into gain and offset terms. See also *Relative Accuracy*.

A/D (ANALOG-TO-DIGITAL) CONVERTER. A circuit used to convert an analog input signal into digital information. All digital meters use an A/D converter to convert the input signal into digital information.

ANALOG OUTPUT. An output that is directly proportional to the input signal.

ASSEMBLER. A molecular manufacturing device that can be used to guide chemical reactions by positioning molecules. An assembler can be programmed to build virtually any molecular structure or device from simpler chemical building blocks.

AUTO-RANGING. The ability of an instrument to automatically switch among ranges to determine the range offering the highest resolution. The ranges are usually in decade steps.

AUTO-RANGING TIME. For instruments with auto-ranging capability, the time interval between application of a step input signal and its display, including the time for determining and changing to the correct range.

BANDWIDTH. The range of frequencies that can be conducted or amplified within certain limits. Bandwidth is usually specified by the -3dB (half-power) points.

BIAS VOLTAGE. A voltage applied to a circuit or device to establish a reference level or operating point of the device during testing.

CAPACITANCE. In a capacitor or system of conductors and dielectrics, that property which permits the storage of electrically separated charges when potential differences exist between the conductors. Capacitance is related to the charge and voltage as follows: $C = Q/V$, where C is the capacitance in farads, Q is the charge in coulombs, and V is the voltage in volts.

CARBON NANOTUBE. A tube-shaped nanodevice formed from a sheet of single-layer carbon atoms that has novel electrical and tensile properties. These fibers may exhibit electrical conductivity as high as copper, thermal conductivity as high as diamond, strength 100 times greater than steel at one-sixth of steel's weight, and high strain to failure. They can be superconducting, insulating, semiconducting, or conducting (metallic). Non-carbon nanotubes, often called nanowires, are often created from boron nitride or silicon.

CHANNEL (SWITCHING). One of several signal paths on a switching card. For scanner or multiplexer cards, the channel is used as a switched input in measuring circuits, or as a switched output in sourcing circuits. For switch cards, each channel's signals paths are independent of other channels. For matrix cards, a channel is established by the actuation of a relay at a row and column crosspoint.

COAXIAL CABLE. A cable formed from two or more coaxial cylindrical conductors insulated from each other. The outermost conductor is often earth grounded.

COMMON-MODE REJECTION RATIO (CMRR). The ability of an instrument to reject interference from a common voltage at its input terminals with respect to ground. Usually expressed in decibels at a given frequency.

COMMON-MODE CURRENT. The current that flows between the input low terminal and chassis ground of an instrument.

COMMON-MODE VOLTAGE. A voltage between input low and earth ground of an instrument.

CONTACT RESISTANCE. The resistance in ohms between the contacts of a relay or connector when the contacts are closed or in contact.

CONTAMINATION. Generally used to describe the unwanted material that adversely affects the physical, chemical, or electrical properties of a semiconductor or insulator.

D/A (DIGITAL-TO-ANALOG) CONVERTER. A circuit used to convert digital information into an analog signal. D/A converters are used in many instruments to provide an isolated analog output.

DIELECTRIC ABSORPTION. The effect of residual charge storage after a previously charged capacitor has been discharged momentarily.

DIGITAL MULTIMETER (DMM). An electronic instrument that measures voltage, current, resistance, or other electrical parameters by converting the analog signal to digital information and display. The typical five-function DMM measures DC volts, DC amps, AC volts, AC amps, and resistance.

DRIFT. A gradual change of a reading with no change in input signal or operating conditions.

DRY CIRCUIT TESTING. The process of measuring a device while keeping the voltage across the device below a certain level (e.g., <20mV) in order to prevent disturbance of oxidation or other degradation of the device being measured.

ELECTROCHEMICAL EFFECT. A phenomenon whereby currents are generated by galvanic battery action caused by contamination and humidity.

ELECTROMETER. A highly refined DC multimeter. In comparison with a digital multimeter, an electrometer is characterized by higher input resistance and greater current sensitivity. It can also have functions not generally available on DMMs (e.g., measuring electric charge, sourcing voltage).

EMF. Electromotive force or voltage. EMF is generally used in context of a voltage difference caused by electromagnetic, electrochemical, or thermal effects.

ELECTROSTATIC COUPLING. A phenomenon whereby a current is generated by a varying or moving voltage source near a conductor.

ERROR. The deviation (difference or ratio) of a measurement from its true value. True values are by their nature indeterminate. See also Random Error and Systematic Error.

FALL TIME. The time required for a signal to change from a large percentage (usually 90%) to a small percentage (usually 10%) of its peak-to-peak value. See also Rise Time.

FARADAY CUP. A Faraday cup (sometimes called a Faraday cage or icepail) is an enclosure made of sheet metal or mesh. It consists of two electrodes, one inside the other, separated by an insulator. While the inner electrode is connected to the electrometer, the outer electrode is connected to ground. When a charged object is placed inside the inner electrode, all the charge will flow into the measurement instrument. The electric field inside a closed, empty conductor is zero, so the cup shields the object placed inside it from any atmospheric or stray electric fields. This allows measuring the charge on the object accurately.

FEEDBACK PICOAMMETER. A sensitive ammeter that uses an operational amplifier feedback configuration to convert an input current into voltage for measurement.

FLOATING. The condition where a common-mode voltage exists between an earth ground and the instrument or circuit of interest. (Circuit low is not tied to earth potential.)

FOUR-POINT PROBE. The four-point collinear probe resistivity measurement technique involves bringing four equally spaced probes in contact with the material of unknown resistance. The array is placed in the center of the material. A known current is passed through the two outside probes and the voltage is sensed at the two inside probes. The resistivity is calculated as follows:

$$\rho = \frac{\pi}{\ln 2} \times \frac{V}{I} \times t \times k$$

where: V = the measured voltage in volts, I = the source current in amps, t = the wafer thickness in centimeters, k = a correction factor based on the ratio of the probe to wafer diameter and on the ratio of wafer thickness to probe separation.

FOUR-TERMINAL RESISTANCE MEASUREMENT. A measurement where two leads are used to supply a current to the unknown, and two different leads are used to sense the voltage drop across the resistance. The four-terminal configuration provides maximum benefits when measuring low resistances.

FULLERENE. Refers to C60, an approximately spherical, hollow, carbon molecule containing 60 carbon atoms arranged in interlocking hexagons and pentagons, reminiscent of the geodesic dome created by architect R. Buckminster Fuller. Sometimes called "buckminsterfullerene" or "buckyball."

GROUND LOOP. A situation resulting when two or more instruments are connected to different points on the ground bus and to earth or power line ground. Ground loops can develop undesired offset voltages or noise.

GUARDING. A technique that reduces leakage errors and decreases response time. Guarding consists of a conductor driven by a low impedance source surrounding the lead of a high impedance signal. The guard voltage is kept at or near the potential of the signal voltage.

HALL EFFECT. The measurement of the transverse voltage across a conductor when placed in a magnetic field. With this measurement, it is possible to determine the type, concentration, and mobility of carriers in silicon.

HIGH IMPEDANCE TERMINAL. A terminal where the source resistance times the expected stray current (for example, 1µA) exceeds the required voltage measurement sensitivity.

INPUT BIAS CURRENT. The current that flows at the instrument input due to internal instrument circuitry and bias voltage.

INPUT IMPEDANCE. The shunt resistance and capacitance (or inductance) as measured at the input terminals, not including effects of input bias or offset currents.

INPUT OFFSET CURRENT. The difference between the two currents that must be supplied to the input measuring terminals of a differential instrument to reduce the output indication to zero (with zero input voltage and offset voltage). Sometimes informally used to refer to input bias current.

INPUT OFFSET VOLTAGE. The voltage that must be applied directly between the input measuring terminals, with bias current supplied by a resistance path, to reduce the output indication to zero.

INPUT RESISTANCE. The resistive component of input impedance.

INSULATION RESISTANCE. The ohmic resistance of insulation. Insulation resistance degrades quickly as humidity increases.

JOHNSON NOISE. The noise in a resistor caused by the thermal motion of charge carriers. It has a white noise spectrum and is determined by the temperature, bandwidth, and resistance value.

LEAKAGE CURRENT. Error current that flows (leaks) through insulation resistance when a voltage is applied. Even high resistance paths between low current conductors and nearby voltage sources can generate significant leakage currents.

LONG-TERM ACCURACY. The limit that errors will not exceed during a 90-day or longer time period. It is expressed as a percentage of reading (or sourced value) plus a number of counts over a specified temperature range.

MAXIMUM ALLOWABLE INPUT. The maximum DC plus peak AC value (voltage or current) that can be applied between the high and low input measuring terminals without damaging the instrument.

MEMS. Microelectromechanical systems. Describes systems that can respond to a stimulus or create physical forces (sensors and actuators) and that have dimensions on the micrometer scale. They are typically manufactured using the same lithographic techniques used to make silicon-based ICs.

MICRO-OHMMETER. An ohmmeter that is optimized for low resistance measurements. The typical micro-ohmmeter uses the four-terminal measurement method and has special features for optimum low level measurement accuracy.

Introduction.....	2
Low Current Measurements	
Measurement Circuit	2
Leakage Currents and Guarding	3
Noise and Source Resistance	3
Zero Drift.....	4
Generated Currents	4
Overload Protection.....	6
AC Interference and Damping	6
Using a Coulombmeter to Measure Low Current.....	7
High Resistance Measurements	
Constant-Voltage Method.....	8
Constant-Current Method.....	8
Guarding.....	9
Settling Time	10
Low-I Application: Avalanche Photodiode Reverse Bias Current Measurements.....	11
High-R Application: Voltage Coefficient Testing of High Ohmic Value Resistors.....	12
Selector Guide	13
Glossary	14

Ask Us Your Application or Product Question.

Glossary continued

MOLECULAR ELECTRONICS. Any system with atomically precise electronic devices of nanometer dimensions, especially if made of discrete molecular parts, rather than the continuous materials found in today's semiconductor devices.

MOLECULAR MANIPULATOR. A device combining a proximal-probe mechanism for atomically precise positioning with a molecule binding site on the tip; can serve as the basis for building complex structures by positional synthesis.

MOLECULAR MANUFACTURING. Manufacturing using molecular machinery, giving molecule-by-molecule control of products and by-products via positional chemical synthesis.

MOLECULAR NANOTECHNOLOGY. Thorough, inexpensive control of the structure of matter based on molecule-by-molecule control of products and by-products; the products and processes of molecular manufacturing, including molecular machinery.

MOSFET. A metal oxide field effect transistor. A unipolar device characterized by extremely high input resistance.

NANO-. A prefix meaning one billionth (1/1,000,000,000).

NANOELECTRONICS. Electronics on a nanometer scale. Includes both molecular electronics and nanoscale devices that resemble current semiconductor devices.

NANOTECHNOLOGY. Fabrication of devices with atomic or molecular scale precision. Devices with minimum feature sizes less than 100 nanometers (nm) are considered products of nanotechnology. A nanometer [one-billionth of a meter (10^{-9} m)] is the unit of length generally most appropriate for describing the size of single molecules.

NANOVOLTMETER. A voltmeter optimized to provide nanovolt sensitivity (generally uses low thermoelectric EMF connectors, offset compensation, etc.).

NOISE. Any unwanted signal imposed on a desired signal.

NORMAL-MODE REJECTION RATIO (NMRR). The ability of an instrument to reject interference across its input terminals. Usually expressed in decibels at a specific frequency such as that of the AC power line.

NORMAL-MODE VOLTAGE. A voltage applied between the high and low input terminals of an instrument.

OFFSET CURRENT. A current generated by a circuit even though no signals are applied. Offset currents are generated by triboelectric, piezoelectric, or electrochemical effects present in the circuit.

OVERLOAD PROTECTION. A circuit that protects the instrument from excessive current or voltage at the input terminals.

PICOAMMETER. An ammeter optimized for the precise measurement of small currents. Generally, a feedback ammeter.

PIEZOELECTRIC EFFECT. A term used to describe currents generated when mechanical stress is applied to certain types of insulators.

PRECISION. Refers to the freedom of uncertainty in the measurement. It is often applied in the context of repeatability or reproducibility and should not be used in place of accuracy. See also Uncertainty.

QUANTUM DOT. A nanoscale object (usually a semiconductor island) that can confine a single electron (or a few) and in which the electrons occupy discrete energy states, just as they would in an atom. Quantum dots have been called "artificial atoms."

RANDOM ERROR. The mean of a large number of measurements influenced by random error matches the true value. See also Systematic Error.

RANGE. A continuous band of signal values that can be measured or sourced. In bipolar instruments, range includes positive and negative values.

READING. The displayed number that represents the characteristic of the input signal.

READING RATE. The rate at which the reading number is updated. The reading rate is the reciprocal of the time between readings.

RELATIVE ACCURACY. The accuracy of a measuring instrument in reference to a secondary standard. See also Absolute Accuracy.

REPEATABILITY. The closeness of agreement between successive measurements carried out under the same conditions.

REPRODUCIBILITY. The closeness of agreement between measurements of the same quantity carried out with a stated change in conditions.

RESOLUTION. The smallest portion of the input (or output) signal that can be measured (or sourced) and displayed.

RESPONSE TIME. For a measuring instrument, the time between application of a step input signal and the indication of its magnitude within a rated accuracy. For a sourcing instrument, the time between a programmed change and the availability of the value at its output terminals. Also known as Settling Time.

RISE TIME. The time required for a signal to change from a small percentage (usually 10%) to a large percentage (usually 90%) of its peak-to-peak amplitude. See also Fall Time.

SENSITIVITY. The smallest quantity that can be measured and displayed.

SETTLING TIME. For a measuring instrument, the time between application of a step input signal and the indication of its magnitude within a rated accuracy. For a sourcing instrument, the time between a programmed change and the availability of the value at its output terminals. *Also known as Response Time.*

SHIELDING. A metal enclosure around the circuit being measured, or a metal sleeve surrounding the wire conductors (coax or triax cable) to lessen interference, interaction, or leakage. The shield is usually grounded or connected to input LO.

SHUNT AMMETER. A type of ammeter that measures current by converting the input current into a voltage by means of shunt resistance. Shunt ammeters have higher voltage burden and lower sensitivity than do feedback ammeters.

SHUNT CAPACITANCE LOADING. The effect on a measurement of the capacitance across the input terminals, such as from cables or fixtures. Shunt capacitance increases both rise time and settling time.

SHORT-TERM ACCURACY. The limit that errors will not exceed during a short, specified time period (such as 24 hours) of continuous operation. Unless specified, no zeroing or adjustment of any kind are permitted. It is expressed as percentage of reading (or sourced value) plus a number of counts over a specified temperature range.

SINGLE ELECTRON TRANSISTOR. A switching device that uses controlled electron tunneling to amplify current. An SET is made from two tunnel junctions that share a common electrode. A tunnel junction consists of two pieces of metal separated by a very thin (~1nm) insulator. The only way for electrons in one of the metal electrodes to travel to the other electrode is to tunnel through the insulator. Tunneling is a discrete process, so the electric charge that flows through the tunnel junction flows in multiples of e , the charge of a single electron.

SOURCE IMPEDANCE. The combination of resistance and capacitive or inductive reactance the source presents to the input terminals of a measuring instrument.

SOURCE-MEASURE UNIT (SMU). An electronic instrument that sources and measures DC voltage and current. Generally, SMUs have two modes of operation: source voltage and measure current, or source current and measure voltage. Also known as source-monitor unit or stimulus measurement unit.

SOURCEMETER. A SourceMeter instrument is very similar to the source-measure unit in many ways, including its ability to source and measure both current and voltage and to perform sweeps. In addition, a SourceMeter instrument can display the measurements directly in resistance, as well as voltage and current. It is designed for general-purpose, high speed production test applications. It can also be used as a source for moderate to low level measurements and for research applications.

SOURCE RESISTANCE. The resistive component of source impedance. See also Thevenin Equivalent Circuit.

SPINTRONICS. Electronics that take advantage of the spin of an electron in some way, rather than just its charge.

STANDARD CELL. An electrochemical cell used as a voltage reference in laboratories.

SUPERCONDUCTOR. A conductor that has zero resistance. Such materials usually become superconducting only at very low temperatures.

SWITCH CARD. A type of card with independent and isolated relays for switching inputs and outputs on each channel.

SWITCHING MAINFRAME. A switching instrument that connects signals among sourcing and measuring instruments and devices under test. A mainframe is also referred to as a scanner, multiplexer, matrix, or programmable switch.

SYSTEMATIC ERROR. The mean of a large number of measurements influenced by systematic error deviates from the true value. See also Random Error.

TEMPERATURE COEFFICIENT. A measure of the change in reading (or sourced value) with a change in temperature. It is expressed as a percentage of reading (or sourced value), plus a number of counts per degree change in temperature.

TEMPERATURE COEFFICIENT OF RESISTANCE. The change of resistance of a material or device per degree of temperature change, usually expressed in ppm/°C.

THERMOELECTRIC EMFS. Voltages resulting from temperature differences within a measuring circuit or when conductors of dissimilar materials are joined together.

THEVENIN EQUIVALENT CIRCUIT. A circuit used to simplify analysis of complex, two-terminal linear networks. The Thevenin equivalent voltage is the open-circuit voltage and the Thevenin equivalent resistance equals the open-circuit voltage divided by the short-circuit current.

TRANSFER ACCURACY. A comparison of two nearly equal measurements over a limited temperature range and time period. It is expressed in ppm. See also Relative Accuracy, Short-Term Accuracy.

TRIBOELECTRIC EFFECT. A phenomenon whereby currents are generated by charges created by friction between a conductor and an insulator.

TRIGGER. An external stimulus that initiates one or more instrument functions. Trigger stimuli include: an input signal, the front panel, an external trigger pulse, and IEEE-488 bus X, talk, and GET triggers.

TWO-TERMINAL RESISTANCE MEASUREMENT. A measurement where the source current and sense voltage are applied through the same set of test leads.

UNCERTAINTY. An estimate of the possible error in a measurement; in other words, the estimated possible deviation from its actual value.

VAN DER PAUW MEASUREMENT. A measurement technique used to measure the resistivity of arbitrarily shaped samples.

VOLTAGE BURDEN. The voltage drop across the input terminals of an ammeter.

VOLTAGE COEFFICIENT. The change in resistance value with applied voltage. Usually expressed in percent/V or in ppm/V.

WARM-UP TIME. The time required after power is applied to an instrument to achieve rated accuracy at reference conditions.

ZERO OFFSET. The reading that occurs when the input terminals of a measuring instrument are shorted (voltmeter) or open-circuited (ammeter).

Introduction..... 2

Low Current Measurements

Measurement Circuit 2

Leakage Currents and Guarding 3

Noise and Source Resistance 3

Zero Drift..... 4

Generated Currents 4

Overload Protection 6

AC Interference and Damping 6

Using a Coulombmeter to Measure Low Current..... 7

High Resistance Measurements

Constant-Voltage Method..... 8

Constant-Current Method..... 8

Guarding..... 9

Settling Time 10

Low-I Application: Avalanche Photodiode Reverse Bias Current Measurements..... 11

High-R Application: Voltage Coefficient Testing of High Ohmic Value Resistors..... 12

Selector Guide 13

Glossary 14

Contact us:

QUOTATION REQUEST

In order to request a quote on any products choose our Keithley office nearest you from the list below and give us a call or send an email.

APPLICATION CONFIGURATION ADVICE

[Click here](#) to discuss your test and measurement challenge and your application with one of our support engineers and receive a free-of-charge consultation.



Specifications are subject to change without notice.
All Keithley trademarks and trade names are the property of Keithley Instruments, Inc.
All other trademarks and trade names are the property of their respective companies.

A GREATER MEASURE OF CONFIDENCE

KEITHLEY

KEITHLEY INSTRUMENTS, INC. ■ 28775 AURORA RD. ■ CLEVELAND, OH 44139-1891 ■ 440-248-0400 ■ Fax: 440-248-6168 ■ 1-888-KEITHLEY ■ www.keithley.com

BELGIUM

Sint-Pieters-Leeuw
Ph: 02-3630040
Fax: 02-3630064
info@keithley.nl
www.keithley.nl

CHINA

Beijing
Ph: 86-10-8447-5556
Fax: 86-10-8225-5018
china@keithley.com
www.keithley.com.cn

FRANCE

Saint-Aubin
Ph: 01-64532020
Fax: 01-60117726
info@keithley.fr
www.keithley.fr

GERMANY

Germering
Ph: 089-84930740
Fax: 089-84930734
info@keithley.de
www.keithley.de

INDIA

Bangalore
Ph: 080-26771071, -72, -73
Fax: 080-26771076
support_india@keithley.com
www.keithley.com

ITALY

Peschiera Borromeo (Mi)
Ph: 02-5538421
Fax: 02-55384228
info@keithley.it
www.keithley.it

JAPAN

Tokyo
Ph: 81-3-5733-7555
Fax: 81-3-5733-7556
info.jp@keithley.com
www.keithley.jp

KOREA

Seoul
Ph: 82-2-574-7778
Fax: 82-2-574-7838
keithley@keithley.co.kr
www.keithley.co.kr

MALAYSIA

Penang
Ph: 60-4-643-9679
Fax: 60-4-643-3794
sea@keithley.com
www.keithley.com

NETHERLANDS

Gorinchem
Ph: 0183-635333
Fax: 0183-630821
info@keithley.nl
www.keithley.nl

SINGAPORE

Singapore
Ph: 65-6747-9077
Fax: 65-6747-2991
sea@keithley.com
www.keithley.com

SWITZERLAND

Zürich
Ph: 044-8219444
Fax: 044-8203081
info@keithley.ch
www.keithley.ch

TAIWAN

Hsinchu
Ph: 886-3-572-9077
Fax: 886-3-572-9031
info_tw@keithley.com
www.keithley.com.tw

UNITED KINGDOM

Theale
Ph: 0118-9297500
Fax: 0118-9297519
info@keithley.co.uk
www.keithley.co.uk

For all countries not listed contact the KIEX department in Germany: Keithley Instruments GmbH/KIEX. Ph: +49-89-84 93 07-62. Fax: +49-89-84 93 07-85. E-Mail: kiex@keithley.com